

WORKING RANCH HORSE PATTERN II

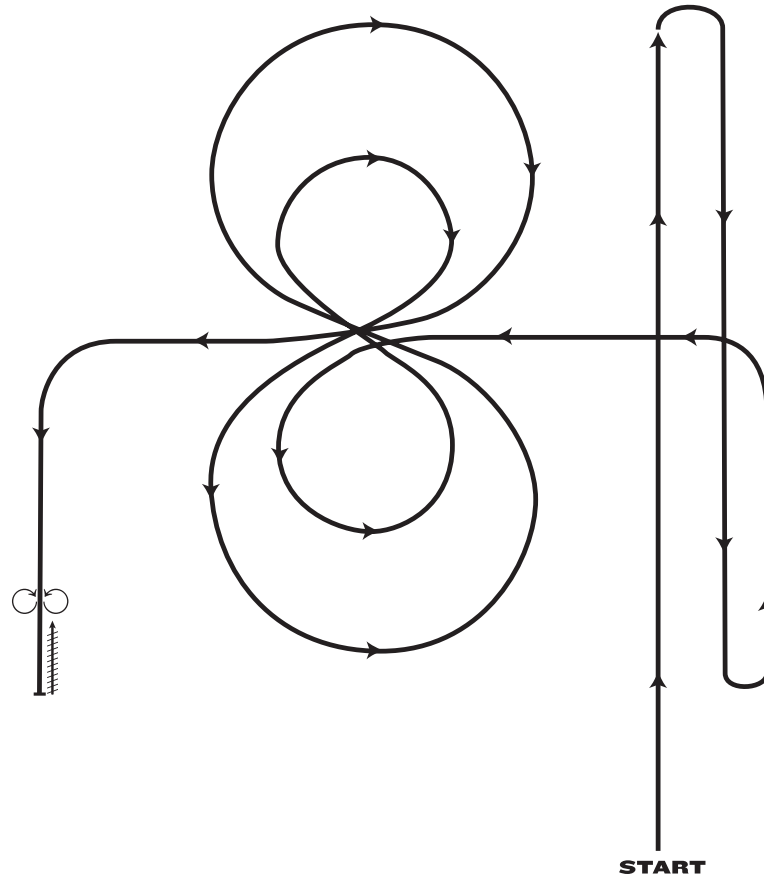

1. Start on right side of arena and lope to far end of arena.
2. Stop and rollback to the right. Continue to other end of arena.
3. Stop and rollback to the left. Continue to center of arena.
4. Lope small, slow circle to left. Change leads.
5. Lope right circle with medium speed. Change leads.
6. Lope large fast circle to left. Change leads.
7. Lope large fast circle to right. Change leads.
8. Continue down arena.
9. Stop and back 10 to 15 feet.
10. Do 360-degree spin right or left.
11. Do 360-degree spin opposite direction taken in
12. Hesitate to show completion of pattern.